



TOWEL AND TISSUE



Solaris Paper®

D67041-N

D67042-N

D67043-N

# Next Generation LoCor® Jumbo Twin Bath Tissue Dispenser

The Next Generation LoCor® jumbo twin bath tissue dispenser is a high-capacity dispensing system that reduces labor costs through fewer roll replacements. Its modern design upgrades the appearance of any washroom while maximizing efficiency and delivering cost savings.

- Sleek and modern dispensing cabinet design
- Extra high 2400' of 2-ply capacity to reduce labor cost and avoid run out
- Bottom sliding door for reserve roll access reduces waste
- Translucent side panels for monitoring paper levels
- Available in matte black, matte gray and stainless finishes
- Meets ADA Guidelines (when installed according to ADA dispenser installation guidelines)

SKU	LoCor® Dispenser	Finish	Case Dimensions	Qty	Case Wt	Product Dimensions	Product Wt
D67041-N	Jumbo Twin Bath Tissue Dispenser	Stainless	21.75" x 12.06" x 5.69"	1	4.4 lb.	21.5" x 11.83" x 4.75"	3.4 lb.
D67042-N	Jumbo Twin Bath Tissue Dispenser	Matte Gray	21.75" x 12.06" x 5.69"	1	4.4 lb.	21.5" x 11.83" x 4.75"	3.4 lb.
D67043-N	Jumbo Twin Bath Tissue Dispenser	Matte Black	21.75" x 12.06" x 5.69"	1	4.4 lb.	21.5" x 11.83" x 4.75"	3.4 lb.



# Get more on the core with LoCor<sup>®</sup> high-capacity towels and tissue.

Together, LoCor<sup>®</sup> dispensers and the innovative reduced core design of LoCor<sup>®</sup> towel and tissue products reduce labor, lower costs and create a cleaner, safer restroom. LoCor<sup>®</sup> paper products are derived from Rapidly Renewable Fiber (RRF)<sup>\*</sup> and contribute to an environmentally friendly building operation while meeting the requirements of the U.S. Green Building Council (USGBC), LEED standards.<sup>\*\*</sup>



by SOLARIS PAPER<sup>®</sup>



USGBC  
MEMBER \*\*

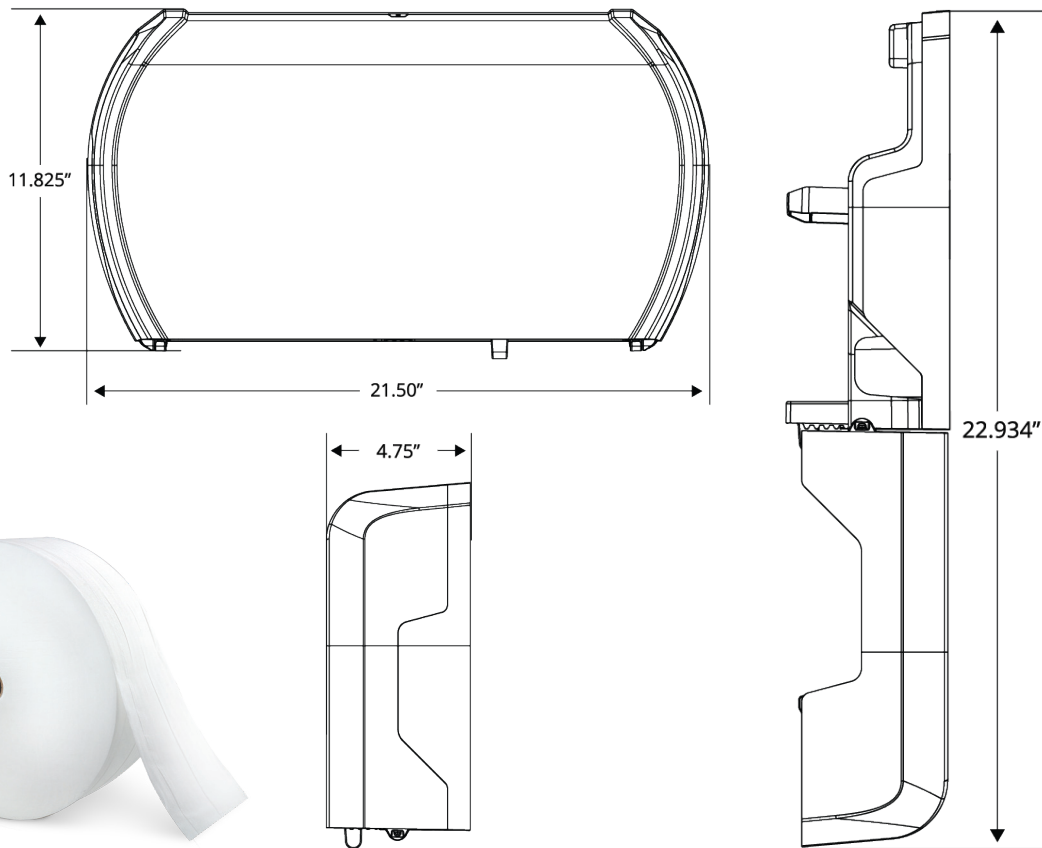

SKU	LoCor <sup>®</sup> Paper Product	Color	Ply	Emboss	Sheet Size	Count	Items/Case	Total Case
26822	LoCor <sup>®</sup> Jumbo Bath Tissue	White	2-Ply	Plain	3.3 x 1200'	1200 ft.	12 rolls	14,400 ft.

\* The RRF (rapidly renewable fiber) logo is a promotional mark of Solaris Paper, Inc. and does not denote any independent or professional environmental certification(s) or certifying organization. Solaris Paper AFH towel and tissue products contain a 20% - 80% virgin rapidly renewable base fiber.

\*\* Solaris Paper towel and tissue products are derived from rapidly renewable resources / fiber and meet the requirements of the U.S. Green Building Council (USGBC) LEED standards per compliance pathways defined in EQc7 (Environmental Quality, credit 7) of LEED EBOM (v4) and IEQc3.3 (Indoor Environmental Quality, credit 3.3) of LEED EBOM (v3). The USGBC logo is a registered trademark of the United States Green Building Council.



**"A Clean Place is a Safe Place"**  
 (702) 982-0881  
[www.new-wave-clean.com](http://www.new-wave-clean.com)

SP-SEL-JTBT-0424